

NOTES: UNLESS OTHERWISE SPECIFIED, INTERPRET DRAWING PER ASME Y14.5M. MATERIALS AND FINISH SHALL BE ROHS COMPLIANT.

1. REMOVE AND DEBURR ALL EDGES AND CORNERS.

2. MARK WITH PART NUMBER, REV, AND VENDOR ID IN LOCATION SHOWN. OR BAG AND TAG WITH PART NUMBER, REV AND VENDOR ID FOR SMALLER PARTS.

REV	DESCRIPTION	DRN	APR	DATE
01	INITIAL RELEASE	RW		04/30/15

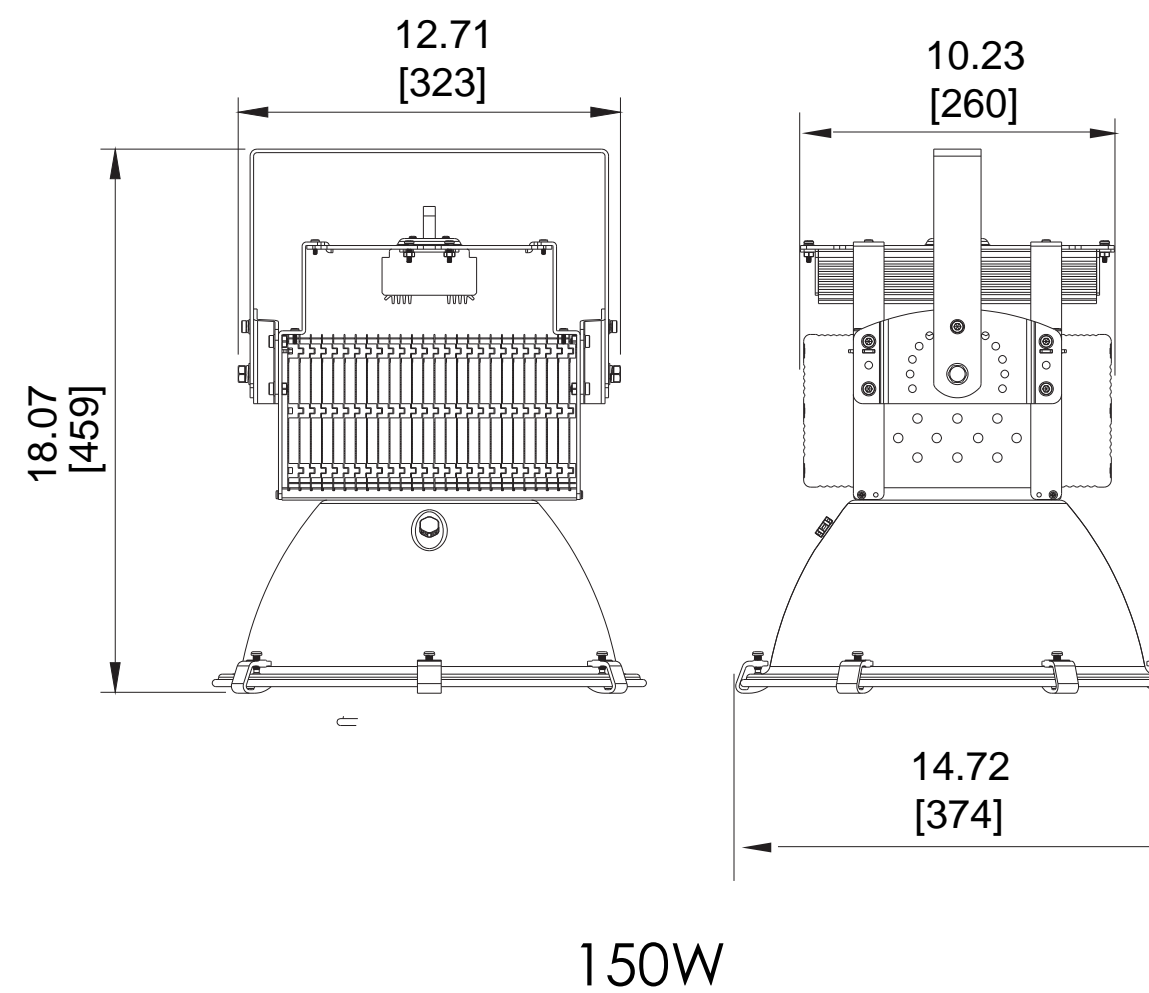
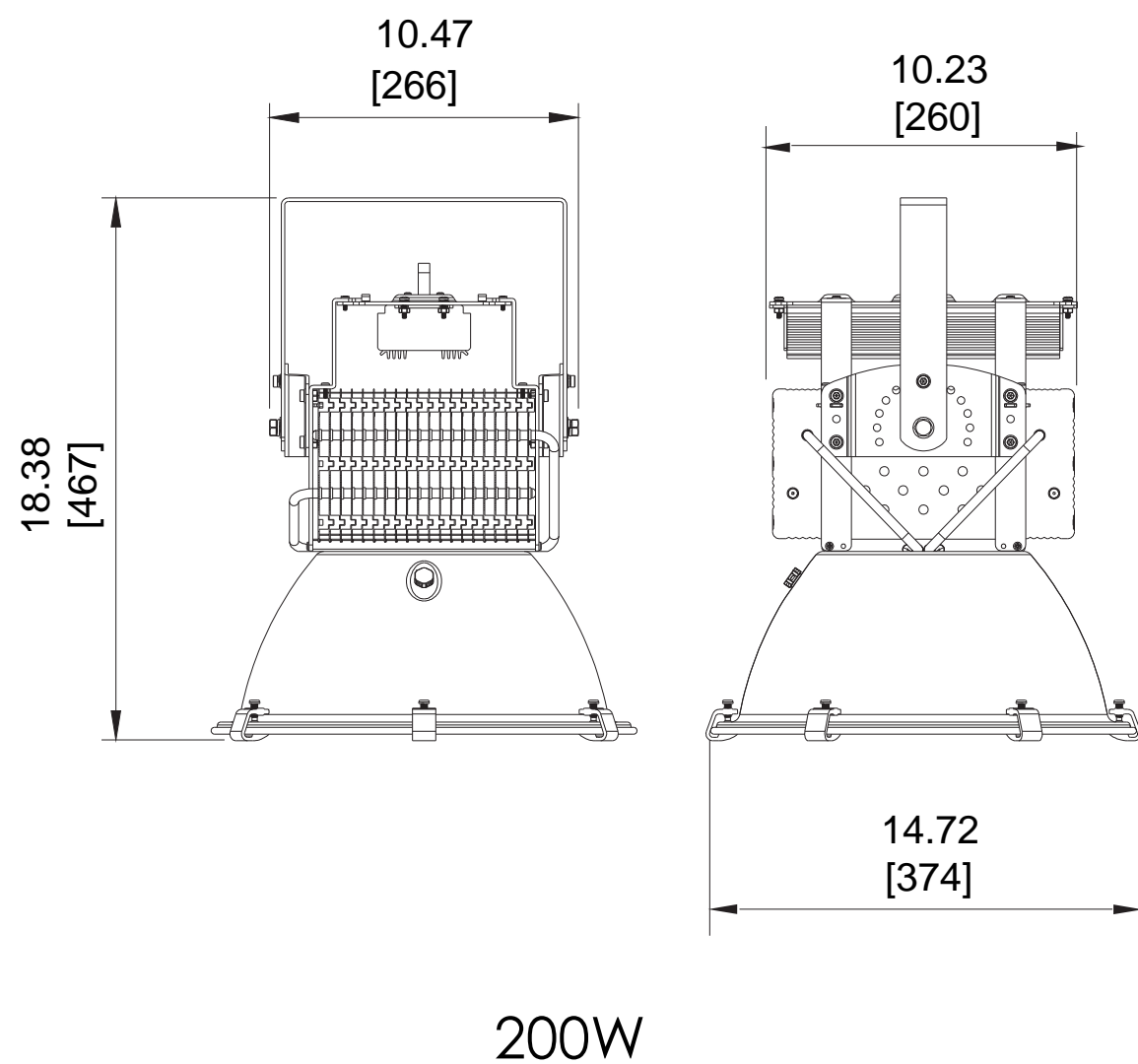
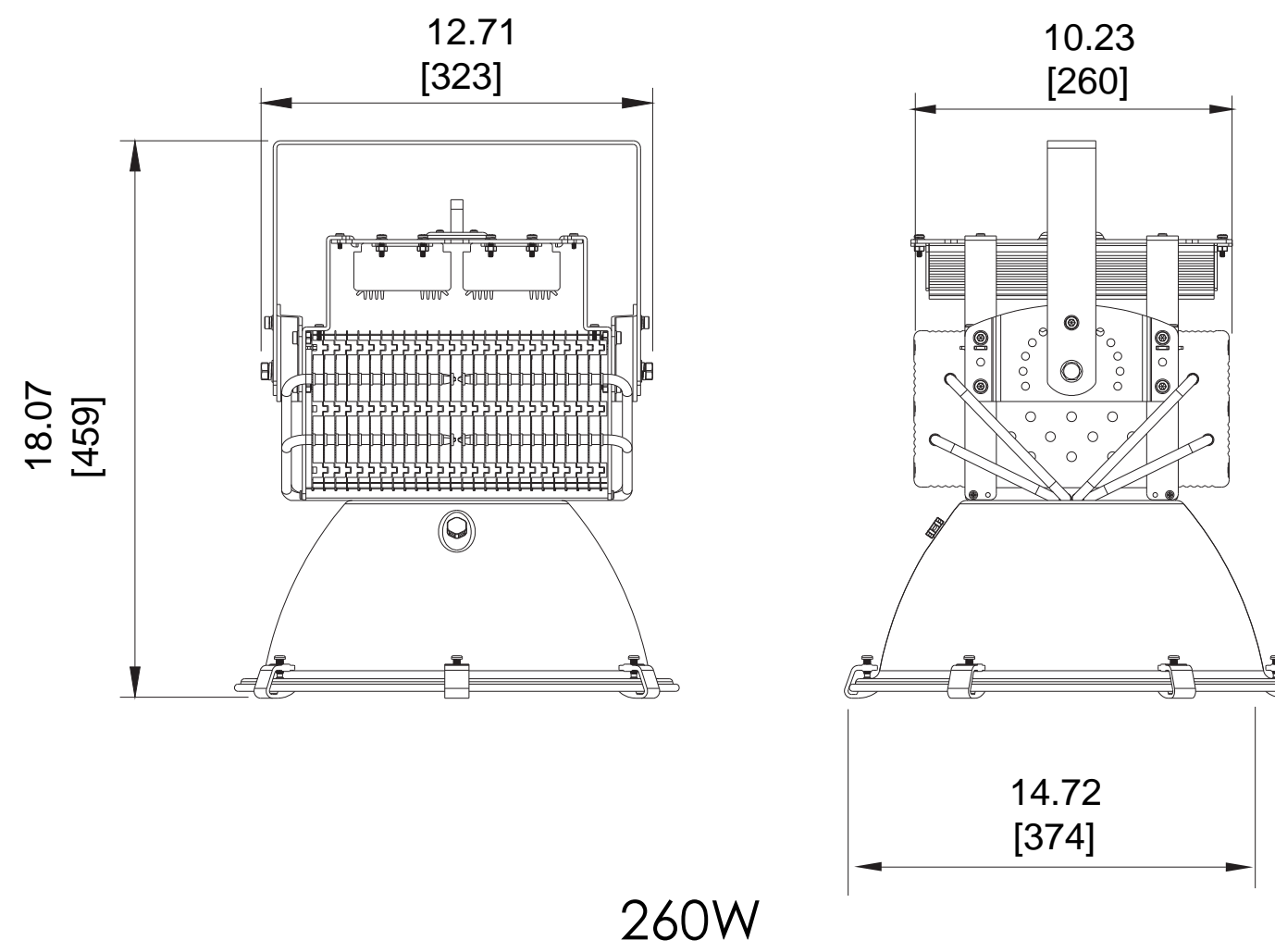
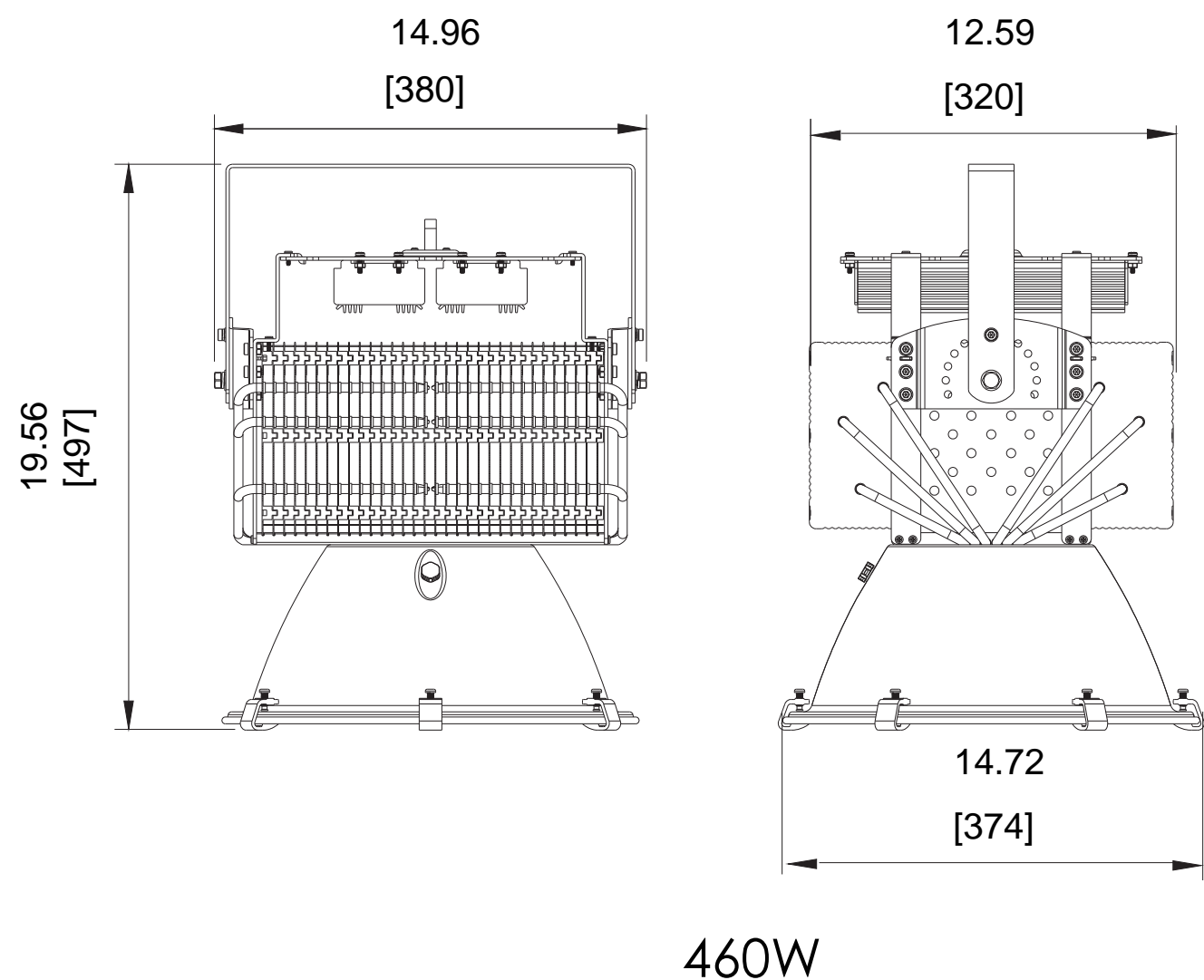

RESILIENT
TOUGH LIGHT

PROPRIETARY AND CONFIDENTIAL
THE INFORMATION CONTAINED IN THIS DRAWING IS THE SOLE PROPERTY OF RESILIENT CORPORATION. ANY REPRODUCTION IN PART OR AS A WHOLE WITHOUT THE WRITTEN PERMISSION OF RESILIENT CORPORATION IS PROHIBITED.

UNLESS OTHERWISE SPECIFIED:
DIMENSIONS ARE IN INCH [MILLIMETERS] TOLERANCE
ANGULAR X.X ± 1°
DECIMAL X.X ± 0.0196 [± 0.5]
DECIMAL X.XX ± 0.0196 [± 0.5]
SURFACE FINISH:

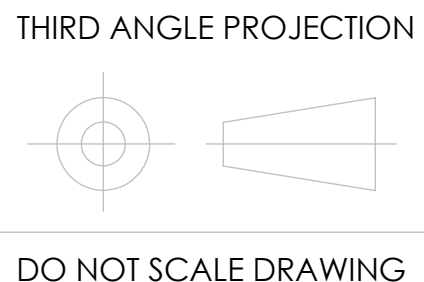

MATERIAL
FINISH

TITLE:

HBL

SIZE
C

DWG. NO.

CODE
MD01

REV

SHEET
OF